

DVB-T: A Solution for ARES Television Operations

Feature this emergency communications digital TV capability at your Field Day event.

Jim Andrews, KH6HTV

The Amateur Radio Emergency Service® (ARES) group of Boulder County, Colorado (BCARES) has been providing TV communication services to the local Office of Emergency Management (OEM), sheriff, police, and fire agencies since 1990.¹ TV has been the most requested service we provide. It has been used to cover natural disasters and large public gatherings. We've covered forest fires, floods, SWAT operations, University of Colorado football games, protest rallies, 10K runs (with 50,000 runners), and more. Originally, we used the old analog 6 MHz wide NTSC broadcast TV standard, which uses Vestigial Upper Side Band (VUSB-TV) modulation. Our typical operation consists of dispatching two-man teams carrying a portable 1 W 70 centimeter TV transmitter in a backpack along with a 12 V, 7 Ah battery. We use ordinary consumer-grade camcorders, and mount both the camcorder and a rubber duck whip antenna on a camera tripod. On 70 centimeter, our analog TV pictures can be received by an ordinary TV configured to receive cable channels. For some operations, we have as many as four transmitters operating simultaneously on cable channels 57 – 60. Most operations are within a half-mile radius of the command post. For forest fires, floods, and big footraces we use higher power 10 W transmitters and Yagi antennas, along with TV repeaters to cover longer distances. We have both a fixed base repeater that covers the eastern half of our county, and a portable TV repeater. We have also used the 1.2, 2.4, and 5.8 GHz amateur bands for point-to-point links using analog FM-TV transmitters.

Most of the time our TV pictures would never be called commercial broadcast quality. We have been plagued with (1) weak signals and snowy pictures, (2) multipath ghosting, (3) mobile flutter, and

often geographic locations where we simply can't get any picture, and (4) in today's high-definition world we had been supplying low-resolution 480i pictures.

Experiments with Digital TV

I started experimenting with digital TV (DTV) in 2011. I had found a relatively inexpensive (\$1100) DTV modulator from R.L. Drake, which implements the USA CATV 64-QAM and 256-QAM modulation formats.² In the autumn of 2011, several other Boulder area hams and I conducted field trials comparing the propagation characteristics of analog VUSB-TV, FM-TV, digital CATV 64-QAM, and DVB-S (satellite standard) systems. We discovered many issues with those DTV systems, which made them unsuitable for our demanding ARES operations. We got very similar performance from the CATV 64-QAM and the DVB-S. Some of the key drawbacks to CATV 64-QAM were the poor receiver sensitivity (-78 dB), and intolerance of multipath propagation. In many situations, even with true

line-of-sight between two Yagi antennas, the receiver would not decode CATV 64-QAM signals due to multipath.

The DTV-T Solution

This past spring, I became aware of a new low-cost solution to digital television. The Spring 2014 issue of *Amateur Television Quarterly* had several articles about hams' great experiences using new DTV equipment from Hi-Des Technologies of Taiwan.³ They offered for sale DTV modulators and receivers that used the European broadcast DTV-T standard. I immediately ordered their model HV-100EH modulator (\$560) and model HV-110 receiver (\$169). We use the European system instead of the USA ATSC 8-VSB broadcast standard because of the cost and equipment size. I have never found any 8-VSB modulators available at a reasonable cost that hams could afford, nor in a small size suitable for portable ARES operations.

The HV-100EH modulator is fully synthesized and covers from 50 to 950 MHz and 1200 to 1350 MHz, thus including the 70 cm, 33 cm, and 23 cm amateur bands where video is permitted by the FCC. It

TV has been the most requested service we provide.

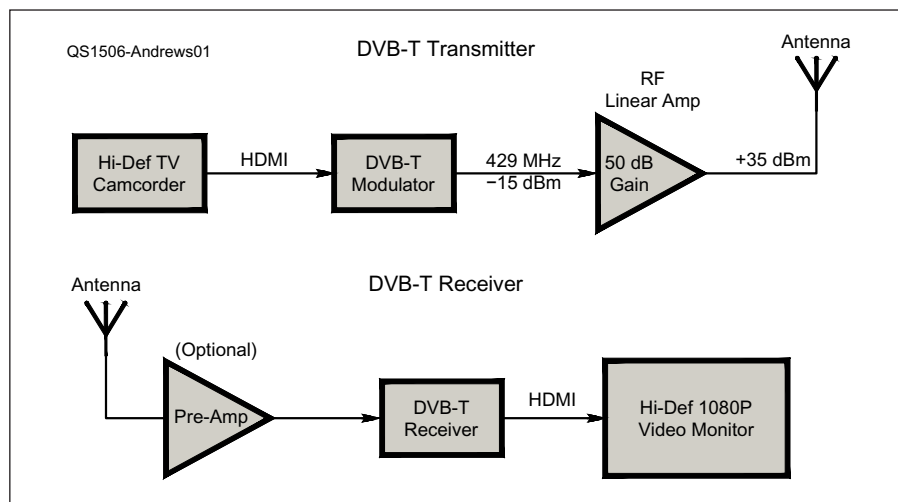

Figure 1 — Block diagram of the DVB-T TV system.



Figure 2 — BCARES crew (Dave Sharp, K10HG, and David Robinson, W0DRR) with TV camera and portable DVB-T TV transmitter at a Colorado University football game.



Figure 3 — Complete DVB-T TV transmitter system includes a (left) Hi-Des modulator, (right) 70 centimeter, 300 mW / 1 W / 3 W linear amplifier, and (center) high definition camcorder.

accepts either standard definition (480i) composite, or high definition (up to 1080p) HDMI video inputs. It encodes the video using either MPEG2 or H.264. Both the operating frequency and bandwidth are programmable. The bandwidth can be set from 2 MHz to 8 MHz in 1 MHz steps (6 MHz is the US broadcast standard). At the 2 MHz bandwidth, the modulator is capable of transmitting only standard definition video. You can select either QPSK, 16-QAM, or 64-QAM modulation format. Programming requires an external PC computer and a USB cable. After programming, the computer may be detached from the modulator. The modulator puts out only -3 dBm RF power and is adjustable downward in 1 dB steps. An RF power amplifier is needed to supply reasonable power levels to an antenna. The RF power amplifier must be very linear to avoid distorting the digital signal and creating unacceptable out of channel emissions.

The HV-110 receiver is likewise fully synthesized and covers from 170 to 950 MHz. The receive frequency and bandwidth are programmable via the supplied remote control. It provides both composite (standard definition only) and HDMI (up to 1080p) video outputs.

TV Receiver Sensitivity

We measured the receiver sensitivity for 6 MHz wide DVB-T channels as -97 dBm for QPSK, -92 dBm for 16-QAM, and -82 dBm for 64-QAM. Because most

of our BCARES operations used low-powered transmitters, we chose QPSK for its superior receiver sensitivity. The QAM modulations allow higher data rates, but we found that was important only for scenes that contained a lot of really fast motion, such as car races and sports. We found very acceptable high definition 1080p performance with normal scenes using QPSK. DVB-T QPSK is 19 dB (3 S units) more sensitive than US CATV 64-QAM signaling. Adding an optional low noise figure pre-amp in front of the Hi-Des Technologies receiver enhanced the QPSK sensitivity still further to -100 dBm. By comparison, a perfect P5 picture (40 dB SNR) using analog VUSB-TV signals requires approximately -60 dBm RF input.

Field Trials

We ran an exhaustive set of field trials this past summer to determine how well the new 70 cm DVB-T system performs compared to 70 cm analog VUSB-TV. Our 70 cm propagation tests used the system of Figure 1 carried in the simple backpack portable arrangement (Figure 2). We compared a 1 W VUSB-TV transmitter with a DVB-T transmitter, which had selectable power levels of 300 mW, 1 W, and 3 W ($+35$ dBm). Figure 3 shows the complete 3 W, 70 cm, DVB-T transmitter and camera.

The first propagation tests simulated a typical SWAT callout, where cameras were

to be deployed in a residential neighborhood. In other tests we carried transmitters around, outside, and inside large buildings in an industrial environment. The

Because most of our BCARES operations used low powered transmitters we chose QPSK for its superior receiver sensitivity.

final acid test involved our BCARES operations at a University of Colorado football game. We deployed roving camera crews all over the stadium, surrounding buildings, and parking lots. Figure

4 depicts a comparison of received digital and analog pictures.

For the Colorado University football game test, we received perfect pictures using 300 mW most of the time. In some locations where previously we could never before receive 1 W analog signal, now either the 1 W or 3 W DVB-T signals got through. The DVB-T system worked far better than the old analog NTSC system.

Conclusions

We learned that if you can receive a P2 quality analog NTSC picture, in all likelihood you will receive a P5 DVB-T picture. A P3 analog signal guarantees a P5 DVB-T picture. A 1 W 70 cm transmitter with antennas 5 feet above ground will provide P5 digital TV, or P3 or better analog picture, in a suburban service area. Raising one of the antennas to 20 feet increases that coverage to a 900-yard radius.

Multipath ghosting, almost always present on the analog pictures, is completely



Figure 4 — Inside the Colorado University police command post. Mark Huff, KB0LRS, at the BCARES TV net control position, monitors live (left) digital DVB-T and (right) analog images.

absent from the DVB-T images, resulting in an always perfect P5 picture. Mobile operation always resulted in “mobile flutter” on the analog picture, even in strong signal areas. DVB-T mobile reception tests at speeds up to 65 mph always resulted in perfect P5 pictures with no breakups.

Very long distance propagation is possible with low power DVB-T signals when a clear line-of-sight path is available. With DVB-T signaling we provide public safety officials with extremely high quality, high-definition (1080p) images.

Notes

¹www.arrl.org/ares

²J. Andrews, KH6HTV, “Modern ATV System Design,” *QST*, Feb 2013, p 46.

³www.hides.com.tw

All photos by the author.

ARRL member and Amateur Extra class licensee Jim Andrews, KH6HTV, was first licensed in 1965. He holds BS, MS, and PhD degrees in electrical engineering from the University of Kansas, and is a Fellow of the IEEE. Jim is founder and former president (now retired) of Picosecond Pulse Labs in Boulder, CO. Jim has been active in ATV and ARES since the mid '70s. He is the builder and trustee for the BCARES TV repeater, W0BCR. Jim and his wife Janet are retired “snowbirds” who spend summers in Boulder and the winters in Maui, Hawaii. Jim is a member of both the Boulder and Maui ham clubs. In Boulder, he mainly operates UHF and microwave ATV. On Maui, Jim’s ham activities include HF voice and PSK31. Jim may be reached at kh6htv@arrl.net.

For updates to this article, see the *QST* Feedback page at www.arrl.org/feedback.

